

MD-SC-R8

NCAP Junction 8m Radius (Using Moshon Data Soft City Pavements)



Moshon Data has designed and developed foam pavements / sidewalks in straight and curved sections to create configurable junction scenarios including Euro NCAP Car to Pedestrian Turning Adult.

The curve pavements are available as a bespoke radius or Euro NCAP R 8m as seen in the below figure from the Euro NCAP Test Protocol - AEB VRU Systems (6 TEST CONDITIONS, page 12).

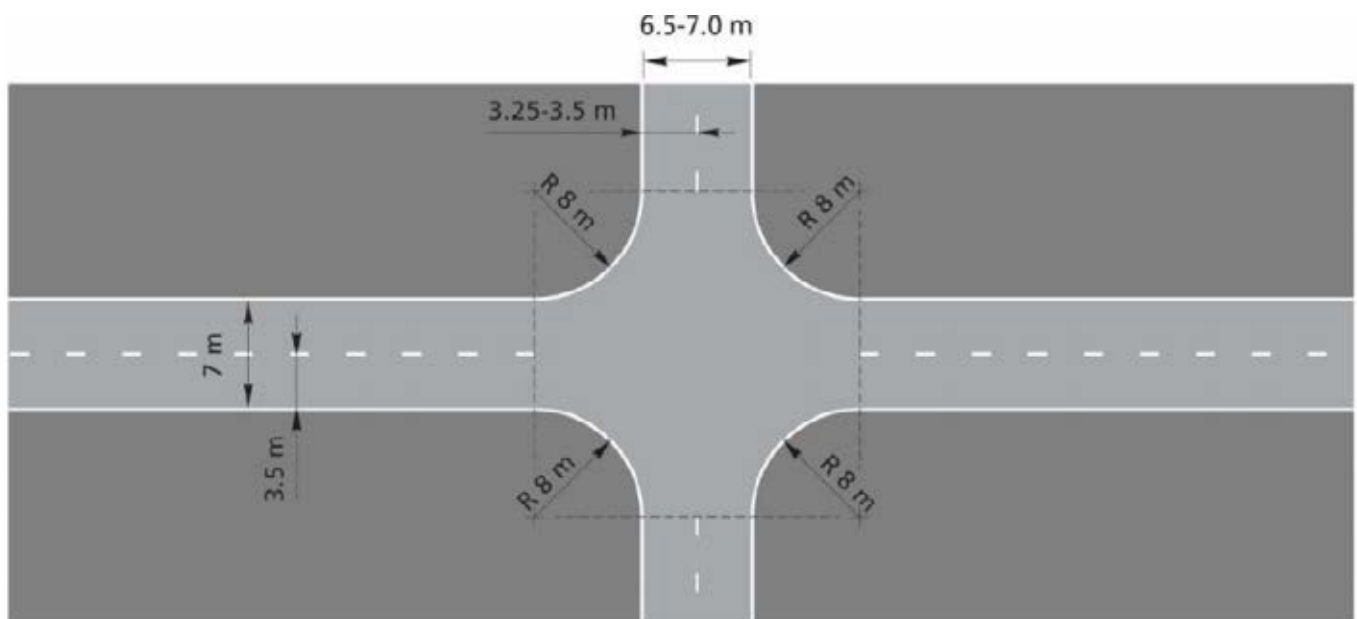

Figure 6-1: Layout of junction and the connecting lanes



"Imparting Knowledge"

MD-SC-R8

NCAP Junction 8m Radius (Using Moshon Data Soft City Pavements)

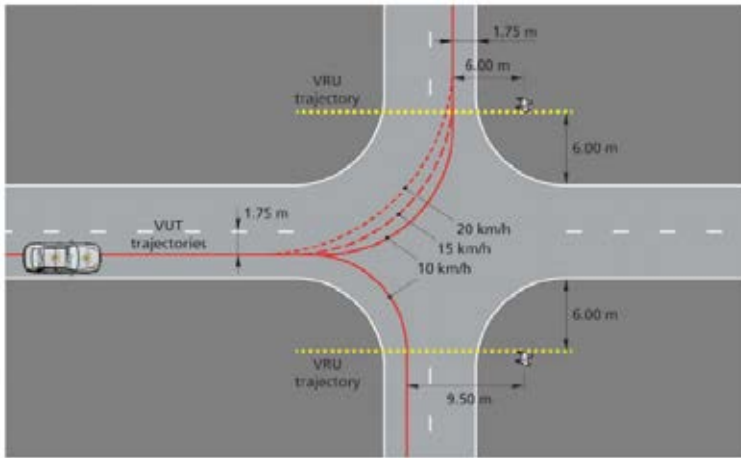

Obstruction Walls, Cityscapes and 3D Buildings can also be added



If you would like more information, contact our team today:

info@moshondata.com
 Tel: +44 (0)1993 209 098
 Mobile: +44 (0)7949 762 820

Technical Specifications

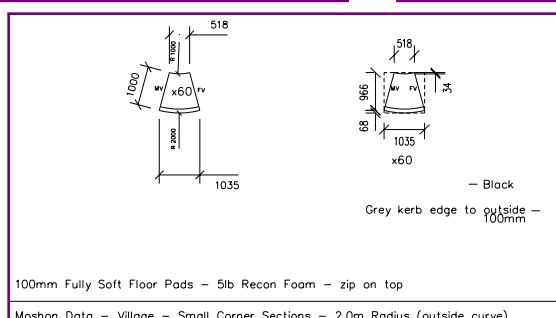
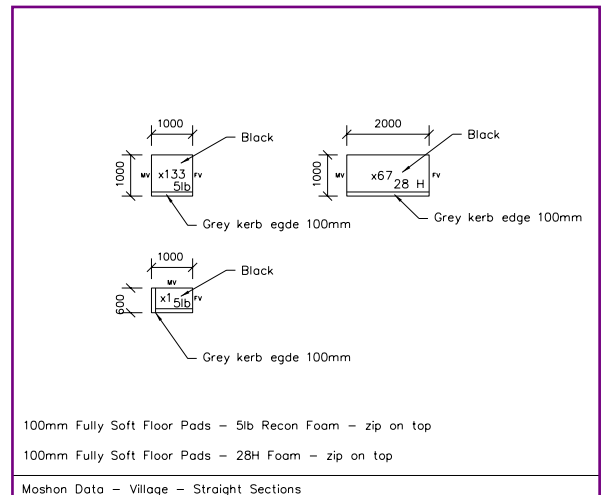
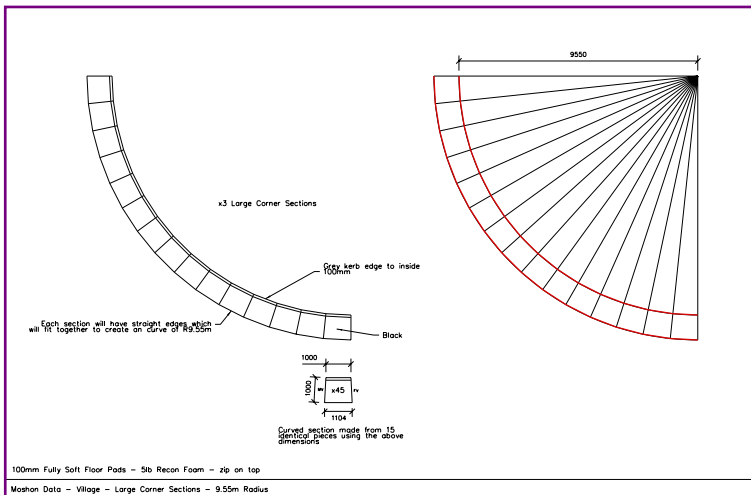

"Imparting Knowledge"